

THIS DRAWING IS UNPUBLISHED. RELEASED FOR PUBLICATION
 © COPYRIGHT BY TYCO ELECTRONICS CORPORATION. ALL RIGHTS RESERVED.

LOC	DIST	REVISIONS					
G	14	P	LTR	DESCRIPTION	DATE	DWN	APVD
		N		REV PER 0G3A-0832-04	28JAN05	JR	TM

AMP WIRE RANGE	Listed FILE E13288	LR7189 Certified
16-14 AWG SOLID OR STRANDED	16-14 AWG SOLID OR STRANDED	16-14 AWG SOLID OR STRANDED

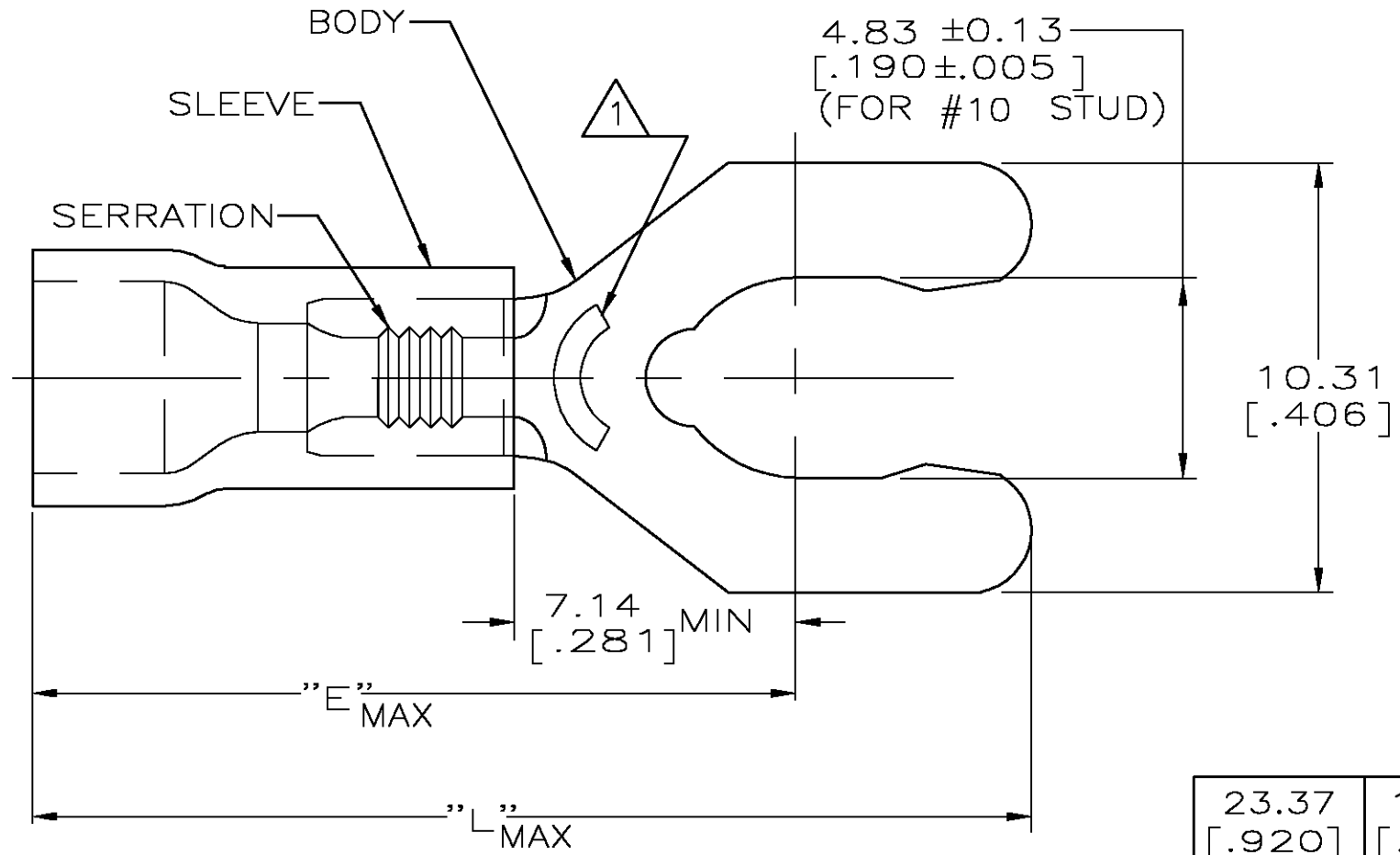

- ① STAMP 10SAMP 16-14* APPROX AS SHOWN
- 2. SEE TABLE FOR WIRE INSUL DIA
- 3. TONGUE MATL THK, 0.79±0.05 [.031±.002]
- ④ MATERIAL: BODY - BRASS PER ASTM B-36
SLEEVE - PVC, COLOR - BLUE

23.37 [.920]	17.70 [.697]	3.00-4.90 [.118-.193]	100	LOOSE PIECE, BOX	8-52957-1
24.61 [.969]	18.95 [.746]	3.81-6.35 [.150-.250]	2500	ON TAPE, REEL	52957-3
24.61 [.969]	18.95 [.746]	3.81-6.35 [.150-.250]	1000	LOOSE PIECE	52957-2
23.37 [.920]	17.70 [.697]	3.00-4.90 [.118-.193]	5000	ON TAPE, REEL	52957-1
23.37 [.920]	17.70 [.697]	3.00-4.90 [.118-.193]	1000	LOOSE PIECE	52957
L	E	WIRE INSUL DIA	QTY	PACKAGE TYPE	PART NO

**AMP INCORPORATED
CUSTOMER SERVICE SYSTEMS**

FOR ADDITIONAL PRODUCT INFORMATION OR COPIES OF DRAWINGS AND TECHNICAL DOCUMENTS: PRODUCT INFORMATION CENTER 1-800-522-6752

FOR APPLICATION TOOLING ASSISTANCE CENTER: TOOLING INFORMATION 1-800-722-1111

FOR ORDER ENTRY: 1-800-526-5142

MAX RECOMMENDED OPERATING TEMPERATURE: 105°C [221° F]

VOLTAGE RATING: 600V MAX (1000V FIXTURE OR SIGN)

CIRCULAR MIL AREA: 1.04-2.62mm² [2,050-5,180] SOLID OR STRANDED

THIS DRAWING IS A CONTROLLED DOCUMENT FOR AMP INCORPORATED. IT IS SUBJECT TO CHANGE AND THE CONTROLLING ENGINEERING ORGANIZATION SHOULD BE CONTACTED FOR THE LATEST REVISION.

THIS DRAWING IS A CONTROLLED DOCUMENT.

DIMENSIONS: mm [INCHES]

TOLERANCES UNLESS OTHERWISE SPECIFIED:

0 PLC	± -
1 PLC	± -
2 PLC	± 0.20 [008]
3 PLC	± -
4 PLC	± -
ANGLES	± -

MATERIAL: TIN PER ASTM B545

DWN: L OLMEDA 26JUN95
 CHK: M ELLIS 26JUN95
 APVD: G NGO 26JUN95

tyco Electronics Tyco Electronics Corporation
Harrisburg, Pa 17105-3608

NAME: TERMINAL, SPRING SPADE, SHORT, PLASTI-GRIP, WIRE SIZE: 16-14

PRODUCT SPEC: UL 486A

APPLICATION SPEC: -

WEIGHT: -

SIZE: A3 CAGE CODE: 00779 DRAWING NO: C-52957 RESTRICTED TO: -

CUSTOMER DRAWING SCALE: 6:1 SHEET: 1 OF 1 REV: N